

$$G_c(f) = G(l, f) \cdot \exp\left(\frac{lf}{0.6u}\right) \quad (7)$$

and increase the accuracy of measurement of the spectral density by a conduction anemometer. Thus, we corrected the spectrum of the signal of a sensor with $l_0 = 1.5$ mm (see Fig. 2).

The present study permits us to give a quantitative estimate of the optimum interelectrode distance of a sensor. In order to improve the signal-to-noise ratio, it is necessary to increase l . However, this is possible only up to a certain value of the interelectrode distance which, for the core of the flow in a circular tube, comes out to be equal to $l/R = 0.15$, since for large values of l the averaging action of the sensor begins to appear. The interelectrode distance is restricted still more by the minimum scale of turbulence, which must be measured under the conditions of the experiment. The obtained results point out the feasibility of correction of spectrum if $l/L \leq 1.5$.

NOTATION

l , interelectrode distance; φ , potential; G , spectral density; k , wave number; $h(x)$, equipment function of the sensor; H^2 , equivalent spectral characteristic of the sensor; L , eddy scale; u , mean velocity; f , frequency; D , tube diameter; u' , root-mean-square value of longitudinal velocity fluctuations; R , radius of the tube; P , signal-to-noise ratio.

LITERATURE CITED

1. S. V. Dotsenko, Theoretical Foundations of Measurements of Physical Fields of an Ocean [in Russian], Gidrometeoizdat, Leningrad (1974).
2. N. I. Bolonov, B. A. Kolovandin, and I. L. Povkh, Heat and Mass Transfer in Non-Newtonian Fluids [in Russian], Energiya, Moscow (1968).
3. I. L. Povkh, N. I. Bolonov, and A. E. Éidel'man, Inzh.-Fiz. Zh., 26, No. 5 (1974).
4. I. L. Povkh, N. I. Bolonov, A. A. Zori, and A. E. Éidel'man, in: Heat and Mass Transfer [in Russian], Vol. 1, Minsk (1972).

INVESTIGATION OF THE EFFICIENCY OF A "JET DIFFUSER"

M. O. Frankfurt

UDC 532.556.4

The power characteristics of a diffuser device formed by a fine turbulent jet blown from an annular conical nozzle in the outlet section of a cylindrical channel were investigated experimentally.

In order to reduce the loss of dynamic pressure during discharge of the flow from the channel into free space, diffuser sections are usually used. Many methods are known for increasing the pressure recovery in these sections, including the method of drawing off or tangential blowing of the boundary layer. In the latter case, the jet is blown out along the surface of the expansion channel and assists stabilization or persistence of breakaway.

A scheme with direct injection of such a jet in the outlet section of a straight channel may be of independent interest. Jet devices of similar type have been suggested, for example, for increasing the thrust of propulsion systems [1]. They may be used also for reducing losses of dynamic pressure in installations with high-temperature flows or corrosive media, where the use of the normal diffusers with impermeable walls in certain cases is difficult.

Translated from Inzherno-Fizicheskii Zhurnal, Vol. 31, No. 2, pp. 248-252, August, 1976. Original article submitted May 4, 1975.

This material is protected by copyright registered in the name of Plenum Publishing Corporation, 227 West 17th Street, New York, N.Y. 10011. No part of this publication may be reproduced, stored in a retrieval system, or transmitted, in any form or by any means, electronic, mechanical, photocopying, microfilming, recording or otherwise, without written permission of the publisher. A copy of this article is available from the publisher for \$7.50.

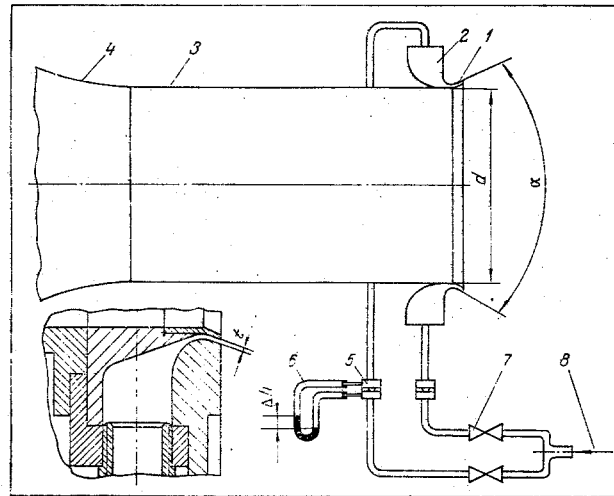

Fig. 1. Diagram of experimental facility: 1) annular nozzle; 2) chamber; 3) cylindrical channel; 4) collector; 5) calibrated jet; 6) U-shaped manometer; 7) valve; 8) air supply.

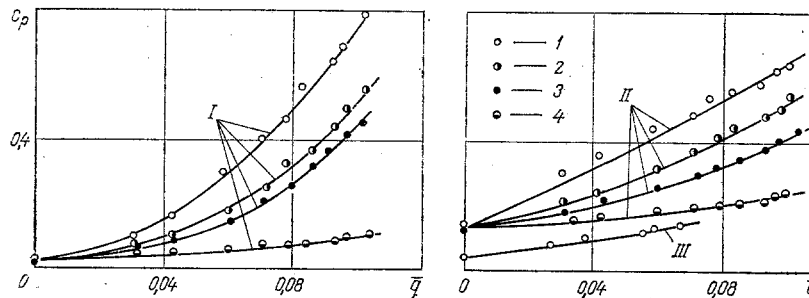

Fig. 2. Curves of $c_p(\bar{q})$ for different values of α , \bar{f} , and \tilde{f} : 1) $\alpha = 60^\circ$; II) $\alpha = 30^\circ$; III) $\alpha = 10^\circ$. 1) $\bar{f} = 0.03$; 2) 0.06; 3) 0.08; 4) $\tilde{f}_\varphi = 0.7$.

The efficiency of such a "jet diffuser," i.e., the expansion section of the channel, bounded along the outer surface by a thin turbulent jet, is not obvious and requires experimental verification. The results of this, as applicable to axisymmetrical channels in the case of turbulent flow, are shown below.

The investigation of the power characteristics of a cylindrical channel with a jet section was carried out with angles of spread of the annular conical jet $\alpha = 10, 30$, and 60° (Fig. 1). The jet was controlled by a nozzle device with interchangeable annular inserts, which enabled the width t_s of the slit to be varied from 0.8 to 2.4 mm. Air reached the slit from an annular chamber, passing through a section with calibrated nozzles. The flow rate q amounted to 10–12% of the flow rate of the air Q passing through the channel.

The tests were carried out on a chamber with a supercharge at a constant average flow velocity in the channel of $u_1 \approx 25$ m/sec and, correspondingly, a Reynolds number of $Re \approx 2.7 \cdot 10^5$ with the discharge flow from the channel into free space. In order to obtain a stable flow, the channel was joined to the chamber through a compartment with a honeycomb and two inlet screens and a nozzle with a 12-fold contraction.

The efficiency of the channel with jet section and with discharge of the flow into free space was estimated by the pressure recovery ratio in the channel c_p and by the magnitude of the total dynamic pressure loss coefficient ζ_p . The coefficient c_p was determined by the change of the pressure drop Δp_1 of the static pressure at the outlet from the channel to the atmosphere. Measurements of the magnitude of Δp_1 were carried out by means of a cascade, located along the axis of the channel. The curves of the pressure recovery coefficient $c_p(\bar{q}, \bar{f})$, obtained in this way with different angles of spread of the jet α and with variation of its efflux velocity u_s and of the ducted section of the slot \tilde{f} , are shown in Fig. 2.

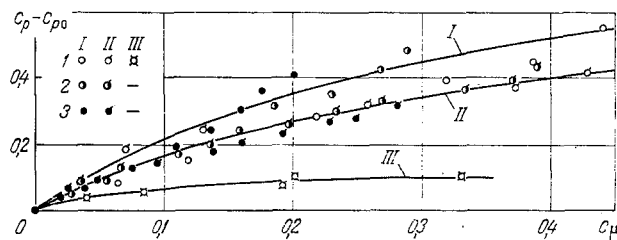

Fig. 3. Curves of $(c_p - c_{p0}) = f(c_\mu)$ for different values of α and \bar{f} . I-III and 1-3) see Fig. 2.

Similar curves of $c_p(c_\mu)$ (Fig. 3) for the jet momentum coefficient c_μ , when $\alpha = \text{const}$ and $\bar{f} = \text{var}$, are of a generalized nature. They show that the coefficient c_μ can be considered as a criterial parameter for estimating the effect of the jet section with a given angle of spread on the pressure recovery ratio in the channel. The curves of $c_p(c_\mu)$ obtained in this case have a well-known analogy with the generalized characteristics of the lift coefficients $c_p(c_y)$, which usually are used when investigating the effect of boundary jets on the controls of aircraft. The total dynamic pressure loss coefficient was determined by taking account of the energy expended on efflux of the jet, for an air-blowing plant efficiency of $\eta_s = 1$, by the formula [2]

$$\zeta_p = \left[\int_{F_1} \bar{u}^3 dF / \int_{F_1} \bar{u} dF - c_p(1 + \bar{q}) + \Delta p_c \bar{q} \right] / (1 + \bar{q}). \quad (1)$$

In calculating the loss coefficients, corresponding to a given air flow rate \bar{q} , the experimental pressure recovery coefficients c_p , the pressure coefficients in the chamber of the nozzle device Δp_c , and the velocity profiles in the cylindrical channel were used.

The characteristics $\zeta_p(\bar{q}, \bar{f})$ shown in Fig. 4 are varied regularly, depending on the magnitude of \bar{f} . With increase of \bar{f} , the optimum values of \bar{q} are shifted into the region of high flow rates, and the minimum values of the coefficients ζ_p are reduced by a factor of 1.3 to 1.5. The form of the characteristics $\zeta_p(\bar{q}, \bar{f})$ in this case depends on two factors: the pressure recovery ratio in the channel and the magnitude of the pressure in the chamber of the jet device corresponding to it. Comparison of these curves shows that over the range $\bar{f} \approx 0.03$ to 0.08 an increase of the area of the slot gives a positive effect. It is accompanied by a somewhat small pressure recovery ratio in the channel and, at the same time, by a marked reduction of pressure in the chamber, which must provide movement of air through the slot with a given area \bar{f} . In the final count, this also leads to a reduction of the dynamic pressure loss in the channel.

Relative to diffusion sections with impermeable walls, the efficiency of the jet device being considered is markedly higher with angles of $\alpha = 60^\circ$. For $\alpha = 30^\circ$, it can be obtained of the same order as for a diffuser with an expansion ratio of $n \geq 3-4$, the length of which is $l/d \geq 2$. With jet blowing angles of order 10° , the use of jet devices has but little effect.

In order to produce a diffuser effect in the outlet section of a rectilinear channel, in principle, nozzle devices with discrete slots also can be used; these are interesting in view of their definite structural advantages. The results of tests of these devices with a relative ducted section of the chopper slot $f = 0.7$ and with the number of jets around the periphery $i = 8$ are shown in Figs. 2 and 4. They show that blowing a jet through a system of discrete slots can lead only to a small increase of the pressure recovery ratio in the channel and to a reduction of the dynamic pressure loss that is considerably less than in the case of a continuous slot.

The effect of a plane screen, installed near the outlet section of the channel, was estimated also as applicable to "jet diffusers." Tests with jet blowing angles of $\alpha = 60^\circ$ showed that the characteristics $c_{p1} \zeta_p(\bar{q})$ depend significantly on the position of the screen, and for every air flow rate \bar{q} there is an optimum position for it. When $\alpha = 60^\circ$ and with an expansion ratio of the jet device of 1.1 to 1.2, the reduction of the dynamic pressure loss in the presence of a plane screen is found to be of the same order as for diffusers with impermeable walls and with the same expansion ratio. When $\alpha \leq 30^\circ$, the efficiency of a "jet diffuser" in the presence of a screen is not increased.

In order to estimate the dynamic pressure loss in a channel with a jet section, the generality of the functions $c_p(c_\mu, \alpha)$ (Fig. 3) can be used, by approximating them to the function

$$c_p \approx c_{p0} + \kappa(\alpha) c_\mu^{0.5}, \quad (2)$$

and the function $\Delta p_c(\bar{q}, \bar{f})$ is represented in the form

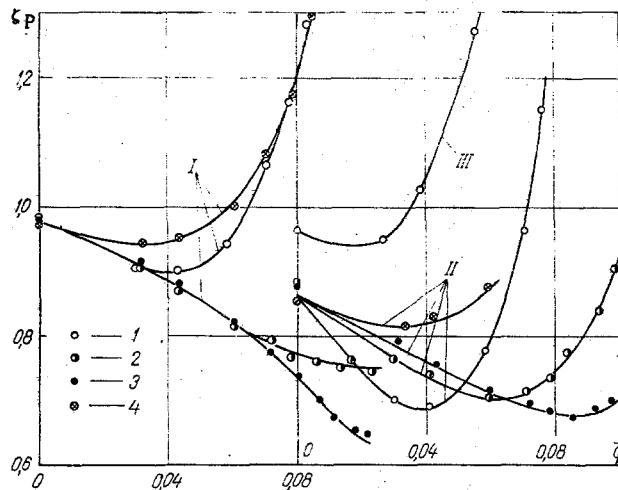

Fig. 4. Curves of $\zeta_P(\bar{q})$ for different values of α , \bar{f} , and \bar{f}_φ . I-III and 1-4) see Fig. 2.

$$\Delta \bar{p}_c = 2\Delta p_c / \rho u_0^2 = \xi \bar{q}^2 / \bar{f}^2, \quad (3)$$

where c_{p_0} is the pressure coefficient in the channel with a jet device when $\bar{q} = 0$ and ξ is an experimental coefficient, depending on the parameters of the slot device. For conical jet devices with angles of $10^\circ \leq \alpha \leq 60^\circ$, $\kappa \alpha \approx 0.068\alpha^{6.15}$. Taking account of Eqs. (2) and (3) when $1/(1+\bar{q}) \approx 1-\bar{q}$; $\bar{q}/(1+\bar{q}) \approx \bar{q}$; and $c_\mu = 2\bar{q}^2/\bar{f}$, formula (1) for the total loss coefficient assumes the form

$$\zeta_P \approx 1 - \bar{q} - [c_{p_0} + \kappa(\alpha)c_\mu^{0.5}] + \xi \bar{q}^3 / \bar{f}^2. \quad (4)$$

The optimum magnitude of the air flow rate \bar{q}_{opt} , corresponding to minimum dynamic pressure losses in the channel when $d\zeta_P/d\bar{q} = 0$, comprises

$$\bar{q}_{opt} \approx 0.58 \bar{f} \xi^{-0.5} [1 + 1.41 \kappa(\alpha) \bar{f}^{-0.5}]^{0.5}, \quad (5)$$

and the minimum magnitude of the loss is

$$\zeta_{Pmin} \approx 1 - c_{p_0} - 0.385 \bar{f} \xi^{-0.5} [1 + 1.41 \kappa(\alpha) \bar{f}^{-0.5}]^{1.5}. \quad (6)$$

The calculations by formulas (5) and (6) coincide satisfactorily with the experimental data and can be used for choosing the parameters of jet devices for cylindrical channels.

NOTATION

$\bar{f} = f/F$; f , area of the annular nozzle; F , cross-sectional area of the channel; $\bar{f}_\varphi = f_\varphi/f$; f_φ , area in the clear of a noncontinuous slot; t , width of the nozzle; d , diameter of the transverse section of the channel; l , length of the channel; n , expansion ratio of the diffuser; $\bar{q} = q/Q$; q , air flow rate through the nozzle; Q , air flow rate through the channel; c_μ , jet momentum coefficient, $c_\mu = 2\bar{q}^2/\bar{f}$; c_p , pressure recovery coefficient; $c_p = 2\Delta p_1/\rho u_1^2$; $\Delta \bar{p}_c = 2\Delta p_c/\rho u_1^2$; Δp , pressure drop in the atmosphere; ρ , density; $\bar{u} = u/u_1$; u , axial velocity component; u_1 , average velocity in the outlet section of the channel; α , mouth angle of the annular conical jet; ζ_P , dynamic pressure loss coefficient; ξ , aerodynamic resistance coefficient of the nozzle device; Re , Reynolds number; $Re = u_1 d/\nu$; ν , kinematic viscosity. Indices: 1, outlet section of channel; c, chamber; s, nozzle exit.

LITERATURE CITED

1. J. P. Morel and P. B. S. Lissman, "The jet flap diffuser: a new thrust augmenting device," AIAA Paper No. 777 (1969).
2. M. O. Frankfurt, Uch. Zap. Tsentr. Aéro-Gidrodinam. Inst., 4, No. 5 (1973).